

Fluorine lined ball valve (Q41FEP/PFA)

Main parts and materials

Name/Material	WCB	CF8	CF3	CF8M	CF3M
Body	WCB	CF8	CF3	CF8M	CF3M
Ball/Stem	WCB	CF8	CF3	CF8M	CF3M
Lined	FEP / PFA / PO / PTFE				
Seat	PTFE / RPTFE				
Bolt/Nut	B7/2H	B8/8	B8/8	B8M/8M	B8M/8M

Technical Specification

Design&Manufacture Standard	HG/T3704, GB/T12237		API 6D
FTF Dimension Standard	HG/T3704, GB/T12221		ASME B16.10
Flange standard	HG/T20592, GB/T9119		ASME B16.5, JIS B2220
Inspection & Test Standard	HG/T13927, JB/T9092		API 598
Normal Diameter	DN15~DN350		1/2"~14"
Normal Pressure	1.0MPa	1.6MPa	150LB
Test pressure	Shell Test	1.5MPa	1.5MPa
	High Pressure Test	1.1MPa	1.1MPa
	Low Pressure Test	0.6MPa	0.6MPa
Temperature Range	FEP:-29℃~120℃, PFA:-29℃~180℃, PTFE:-29℃~150℃		
Applicable Medium	Strong corrosion medium: Hydrochloric acid, Nitric acid, Hydrofluoric acid, Liquid chlorine, Sulfuric acid and Aqua regia etc.		

氟材料压力温度曲线
Pressure-Temperature Curve

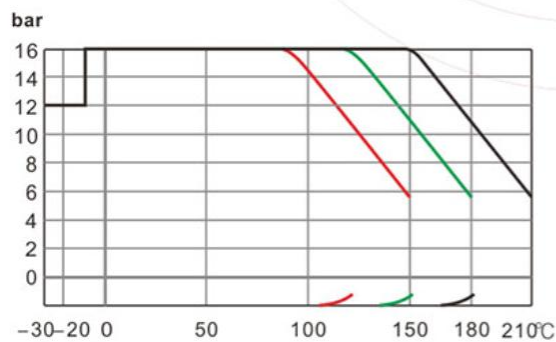

真空 Vacuum: 0.1mbar
备注 Note: — PFA — PTFE — FEP

流量特性图
Flow Characteristic

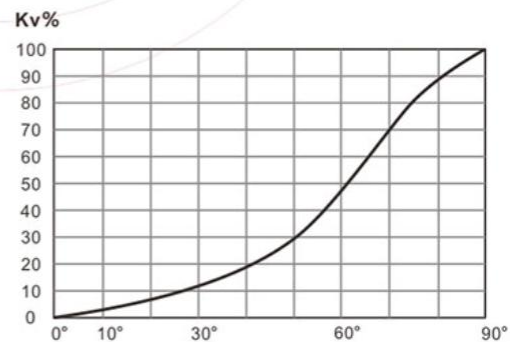

阀位角度 Valve Position Angle
1Cv=1.167Kv

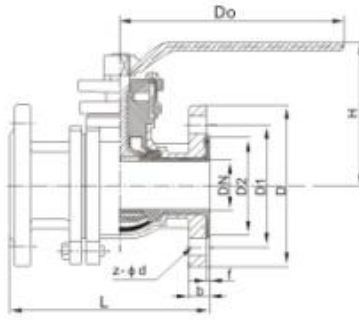

衬氟O型球阀(Q41F46)

衬氟V型电动调节球阀(VQ41F46)

The main connection size

DN (mm)	PNS (Inch)	L	D	D1	D2	f	b	Z-Φd	Do	H
15	1/2	140	95	65	45	3	15	4-14	140	90
20	3/4	140	105	75	55	3	17	4-14	140	100
25	1	150	115	85	65	3	17	4-14	180	105
32	1-1/4	165	140	100	75	3	19	4-18	180	120
40	1-1/2	180	150	110	85	3	19	4-18	225	140
50	2	200	165	125	100	3	21	4-18	225	150
65	2-1/2	220	185	145	120	3	21	4-18	360	160
80	3	250	200	160	135	3	21	8-18	420	215
100	4	280	220	180	155	3	23	8-18	420	240
125	5	320	250	210	185	4	24	8-18	520	250
150	6	360	285	240	210	4	26	8-23	520	290
200	8	400	340	295	265	4	26	8/12-23	240	340
250	10	450	395	350	320	4	28	12-23/26	240	380