

ELECTRIC PINCH VALVE

1- Main of components:

Body, sleeve, Stem, pinch rod, side guide rod, Hand wheel etc.

2- Working principle:

when rotate the handle clockwise, valve stem drive the splint and compress sleeving to close valve, conversely, open the valve. So splint under the pull rod upper and downer to complete the work, because of the rubber sleeve can not sustain heavy strength, so when close it, operator feel a little collide is be ok, forbid to use other tools;

This valve can install on the pipe for free, no fluent direction limit, long term usage, if there is abrasion or leaks, just to remove the valve to replace a new valve core, the valve can use for a long time for economical and practical.

3- Installation and maintenance:

A. Could install it in any part of pipe and don't limit of the medium flow direction.

B. Low maintenance cost, don't need change the seat of valve, sealing material etc, only need change the rubber of sleeving.

4- Functions of Manual Pinch Valves and advantages:

A. Pinch valves can be used for On/Off, as well as throttling services

B. Pinch valves are ideal for on/off services because of their straight through design that allows for uninhibited flow

C. Straight through designs also have very little pressure drop between the inlet and outlet.

D. The effective throttling range of a pinch valve is usually between 10% and 95% of the rated flow capacity

E. Low maintenance

F. Low weight and easy operation

G. Easy changing the rubber sleeving and don't need stock other parts except the rubber sleeving.

5- Main property of the sleeve

Rubber quality	Application examples	Temperature range	Typical media
EPDM	Chemical applications: Applicable to 75% of all industrial chemical applications.	-40°C - +110°C	Concentrated and oxidizing chemicals.
NR	High wear applications.	-40°C - +80°C	Abrasive materials, diluted acids, alkali & chemicals.
NBR	Applications involving oils, fats and hydrocarbon.	-30°C - +100°C	Oil, fats, fuels hydrocarbon, lubricants.
CR	Special-purpse chemical application: Resilient to ozone and averse weather	-40°C - +100°C	Chemicals, acids, several solvents, aliphatic oils, fats, lubricants
IIR	Special-purpse chemical application: Impermeable to gas	-40°C - +100°C	Concentrated and acidic chemicals, vegetable oil.

6- Sleeve design

SLEEVE DESIGN



Outer layer:
protect the sleeve

Reinforced cords:
give the sleeve its pressure retraining capability

Inner layer:
resistant to wear&chemical

7- Main material of parts

Name	Material
Body	Aluminium alloy, Cast iron, Cast steel, Stainless steel
Sleeve	NR, EPDM, NBR, CR, IIR
Stem	Carbon steel, Stainless steel, Alloy steel
Pinch rod	Ductile iron
Side guide rod	Carbon steel, Stainless steel,
Actuator	380V or 220V
Acceptable other special requirements of the material	

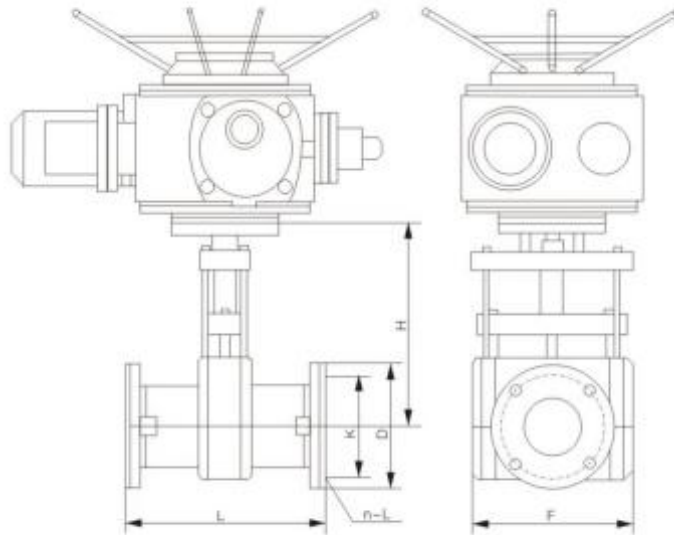

8- Main dimension (mm)

DN	PN(Bar)	L	L1	L0	D	D1	Z-φ
50	1-16	210	160	60	160	125	4-18
65	1-16	250	199	74	180	145	4-18
80	1-16	300	222	88	195	160	4-18
100	1-16	350	250	106	215	180	8-18
125	1-10	430	318	134	245	210	8-18
150	1-10	500	350	158	280	240	8-23
200	1-6	645	446	206	335	295	8-23
250	1-6	800	516	256	395	350	12-23
300	1-4	940	562	304	440	400	12-23
350	1-4	840			500	460	16-23

400	1-4	915			580	525	16-25
-----	-----	-----	--	--	-----	-----	-------